

BAT-LEAD-4V4AH-WL (4V4.0Ah/20hr)



General Series

General Series Valve Regulated Lead Acid batteries are designed with AGM (Absorbent Glass Mat) technology, high performance plates and electrolyte to gain extra power output for common power backup system applications widely used in the field of UPS, Emergency Lighting System.

Application

- Alarm System
- Cable Television
- Power tools
- Emergency Power System
- Security System
- Solar
- Medical Equipment
- UPS
- Communication Equipment
- Control Equipment
- Toys

General Features

- Sealed and maintenance free operation.
- Non-Spillable construction design.
- ABS containers and covers optional.
- Safety valve installation for explosion proof .
- High quality and high reliability.
- Exceptional deep discharge recovery performance.
- Low self discharge characteristic.
- Flexibility design for multiple install positions.

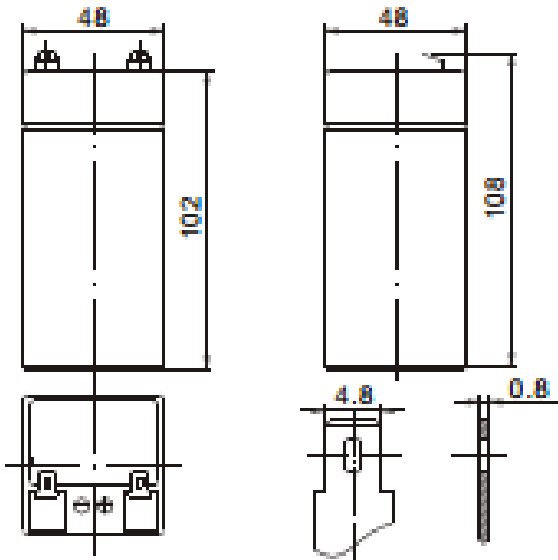

CONSTRUCTION

Component	Positive plate	Negative plate	Container	Cover	Safety valve	Terminal	Separator	Electrolyte
Raw material	Lead dioxide	Lead	ABS	ABS	Rubber	Copper	Fiberglass	Sulfuric acid

TECHNOLOGY PARAMETER

Battery model	BAT-LEAD-4V4AH-WL			
Designed Floating Life	3~5 Years			
Capacity (25 °C)	20hR(0.2A, 3.50V)	10hR(0.39A,3.50V)	5hR(0.66A, 3.50V)	1hR(2.63A, 3.20V)
	4.0Ah	3.9Ah	3.3Ah	2.63Ah
Dimensions	Length	Width	Height	Total Height
	48±1mm	48±1mm	101±1mm	107±1mm
Approx. weight (±5%)	0.45Kg (1.00lbs)			
Internal resistance	Full charged at 25°C Approx. 20mOhms			
Self discharge	3% of capacity declined per month at 25°C(average)			
Capacity Affected by Temp.(20HR)	40 °C	25 °C	0 °C	-15 °C
	102%	100%	85%	65%
Charge Voltage (25°C)	Cycle use		Float use	
	4.8-5.0V(-15mV/°C), max. Current: 1.2A		4.5-4.6V(-10mV/°C)	

BAT-LEAD-4V4AH-WL (4V4.0Ah/20hr)

Constant current discharge ratings-amperes at 25°C

End Point Volts/Cell	5min	10min	15min	30min	1h	3h	5h	10h	20h
1.60V	14.2	9.96	7.58	4.27	2.63	1.10	0.72	0.410	0.210
1.65V	13.5	9.51	7.21	4.10	2.58	1.07	0.70	0.403	0.205
1.70V	12.7	8.98	6.84	3.92	2.52	1.03	0.68	0.395	0.203
1.75V	11.9	8.44	6.47	3.72	2.41	0.99	0.66	0.390	0.200
1.80V	11.1	8.00	6.10	3.54	2.29	0.94	0.64	0.382	0.196

Constant power discharge ratings-watts at 25°C

End Point Volts/Cell	5min	10min	15min	30min	1h	3h	5h	10h	20h
1.60V	26.3	18.4	14.1	7.98	4.94	2.08	1.37	0.78	0.40
1.65V	24.9	17.5	13.3	7.62	4.82	2.01	1.32	0.77	0.39
1.70V	23.3	16.4	12.6	7.25	4.68	1.93	1.28	0.75	0.39
1.75V	21.7	15.4	11.8	6.85	4.46	1.84	1.23	0.73	0.38
1.80V	20.0	14.4	11.0	6.44	4.20	1.73	1.18	0.71	0.37

