

USER MANUAL

Model: CD001
Caller ID Phone



Thank you for choosing WELL. Please read carefully the following instructions and keep them within reach.

Reorder no.: **black - PHONE-CORD-CD001BK-WL**

white - PHONE-CORD-CD001WE-WL

INTRODUCTION

Thank you for purchasing our newest phone with LCD display. This manual is designed to familiarize you with this phone. To get maximum use from your new phone, we suggest that you read this Instruction Manual carefully before operating it.

SAFETY INSTRUCTION

When using your telephone equipment, the following basic safety precautions should always be followed to reduce the risk of fire, electric shock and injury to persons:

1. Read and understand all instructions.
2. Follow all warnings and instructions.
3. Unplug the product from the wall outlet before cleaning. Do not use liquid cleaners or aerosol cleaners. Use damp cloth for cleaning.
4. Do not place this product on an unstable cart, stand or table. The product may fall, causing serious damage to the product.
5. Do not overload wall outlets and extension cords as this can result in the risk of fire or electric shock.
6. Never push objects of any kind into this product through cabinet slots as they may touch dangerous voltage points or short out parts that could result in a risk of fire or electric shock. Never spill liquid of any kind on the product.
7. Do not use this unit during an electrical storm, move or disconnect the unit, there may be a remote risk of electronic shock from lightning and thunder.

FEATURES

- FSK/DTMF system compatible
- 16-digit LCD display with calendar
- 28 incoming calls and 5 outgoing calls
- 1 one-touch memories
- VIP number can be set
- 5-digit area code function
- Pre-dial and edit function
- Mute function
- Pause function
- 5 levels LCD contrast adjustable
- 8 kinds of ringing tone for selection
- Special ringing tone for VIP calls
- Pulse and tone dialing mode compatible
- 2 levels hands-free volume control
- Hands free dialing and speakerphone
- Thunder-proof and anti-dialing from parallel phones function
- Redial and auto-redial function
- Flash time 600ms
- Ring LED indicator

➤ Wall mounting option

LOCATION DESCRIPTION

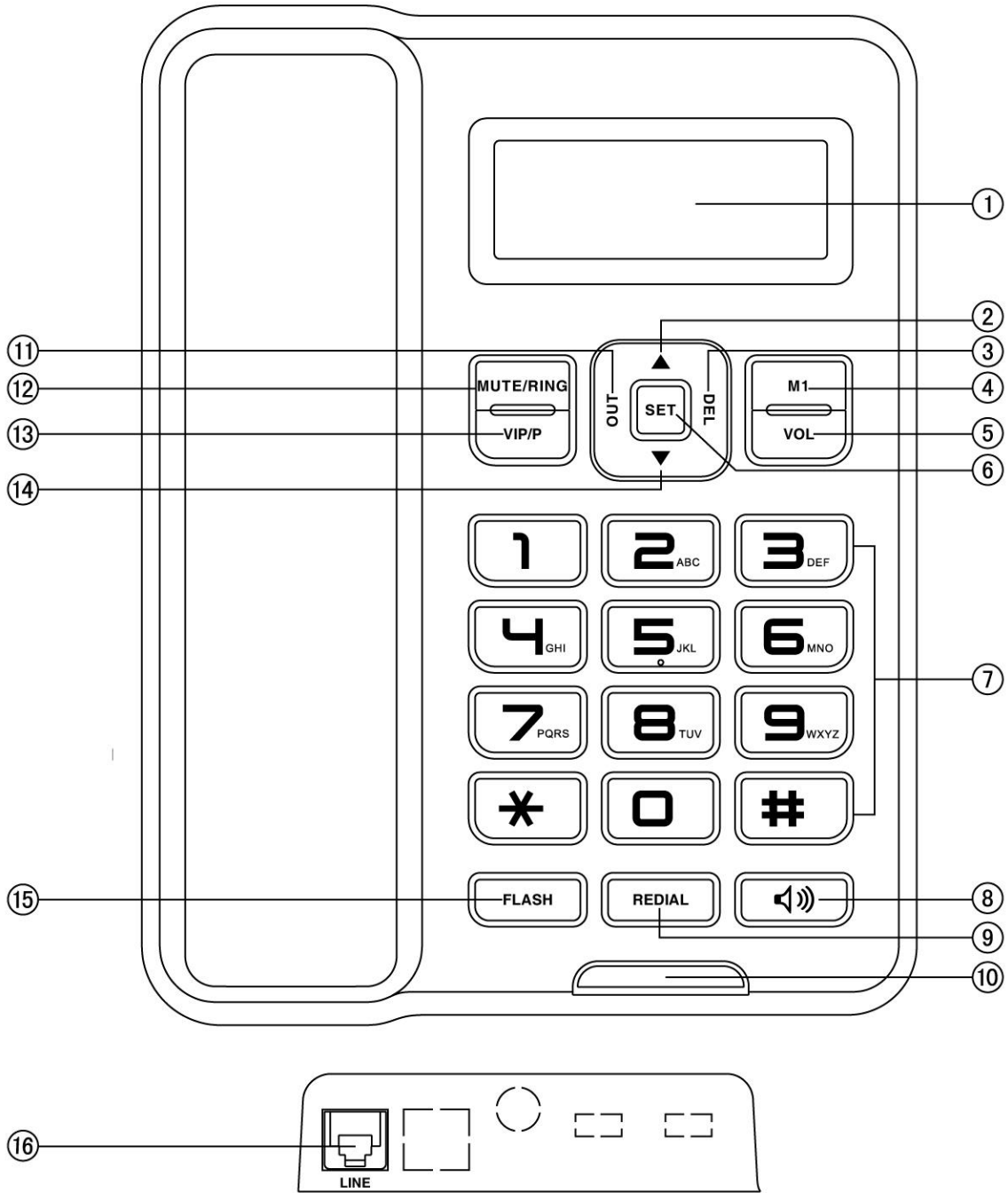

- | | | | |
|-------|-----------------|-------------|---------|
| ① LCD | ⑤ VOL | ⑨ REDIAL | ⑬ VIP/P |
| ② UP | ⑥ SET | ⑩ RING LED | ⑭ DOWN |
| ③ DEL | ⑦ NUMERICAL KEY | ⑪ OUT | ⑮ FLASH |
| ④ M1 | ⑧ H.F | ⑫ MUTE/RING | ⑯ LINE |

GETTING STARTED

1. Insert one end of the line cord to the line jack of the base and the other end to the wall outlet of exchanger. The time and date will be display on the liquid crystal screen after the line cord is inserted.
2. If you want to keep incoming and outgoing calls information even when the line cord has lost the connection, you can insert 3×1.5AA batteries.
3. Connect the handset and the unit with coiled line.
4. Set the dialing mode to correct mode according to the directions from your local telecom.
5. Apply for the caller ID service from your local telecom office.

WALL MOUNTING

1. The telephone can be wall mounted. Mark two points 72mm apart on the wall. Drill holes into the wall 72mm apart. Insert plugs and screws (not included) in the wall and clip in the telephone base by inserting the screws into the wall mount slots at the back of the telephone base. Adjust the screws if necessary.

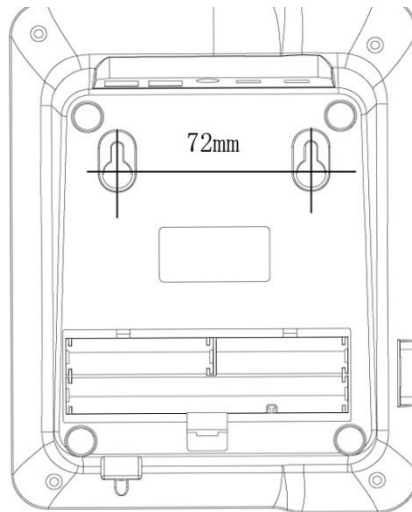

2. Slide out the parking hook as indicated. Turn it around and slide back into position again. Place the handset on the cradle with the parking hook on the cradle arranged to fit into the parking recess under the earpiece on the handset.

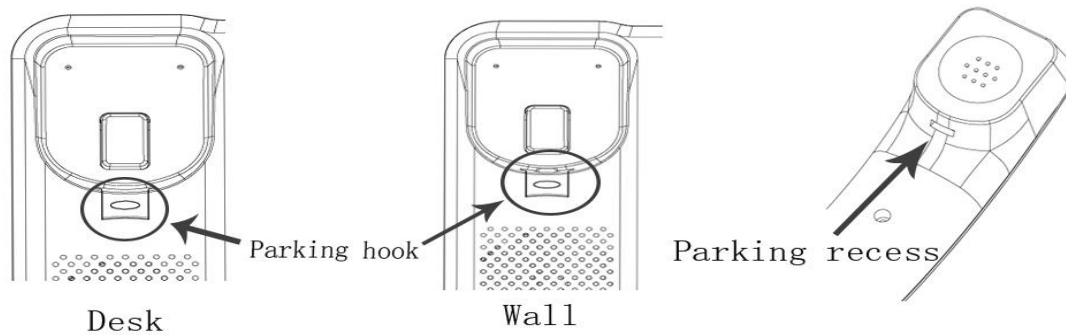



RECEIVE CALLS

The unit will ring when a call comes, if you have subscribed caller ID service to your local telecom, LCD will display month, date, time, the incoming call and **NEW** icon sequentially. If a missed call number comes twice or more times, the **REPEAT** will be displayed on the LCD.



➤ From the handset

1. Pick up the handset and talk to the other end.
2. After finished, return the handset to the base.

➤ Switch to speakerphone

1. When talking by handset, press  key and return the handset to the base.
2. After finished, press  key again.

➤ From the speakerphone

1. When the telephone rings, press  key and talk to the caller.
2. After finished, press  key again.



Note: Generally telecom transmits the incoming message between the first ring and the second ring. So please answer the telephone after the second ring.

MAKE CALLS

➤ From the handset

1. Pick up the handset.
2. When hearing the dialing tone, dial the desired number. The LCD will start to time the conversation.
3. After finished, return the handset to the base.

➤ From the speakerphone

1. Press  key.
2. When hearing the dialing tone, dial the desired number. The unit will start to time the conversation.
3. After finished, press  key again.

➤ Redial function

1. Pick up the handset, or press  key.
2. Press **REDIAL** key, the number dialed will be dialed out again.

➤ **Pre-dial function**

1. In on-hook state.
2. Dial the desired number, if any mistake, use **DEL** key to delete.
3. Press **REDIAL** key, the number will be dialed out.

➤ **Auto-redial**

1. Press  key, dial a number, if you hear an engaged tone.
2. Press **REDIAL** key and the last dialed number will be redialed automatically at every 6 seconds until the line is through.

While auto-redialing, pick up the handset or press  key will end the dialing.

REVIEW, CALL BACK AND DELETE INCOMING CALL

The telephone can record 28 incoming calls. When the memory is full, the earliest one (except VIP) will be replaced.

A secret number comes, LCD displaysp....

If incoming call is from an area without Call ID service, LCD displayso....

➤ **Review incoming call**

1. In on-hook or off-hook state.
2. Press ▲ or ▼ key to review the incoming messages.
3. When all records are checked, LCD displays ...END...

➤ **Call back incoming call**

1. In on-hook or off-hook state, press ▲ or ▼ key to check the desired number.
2. Press **REDIAL** key, the number is dialed out automatically.
3. Or press **REDIAL** key twice, the telephone auto-add “0” to long distance call number and dial it out.

Call back the local area call: The telephone can auto filter local area code, after setting the local area code (Refer to local area code setting).

Call back the long distance call:

If LCD displays a number which is long distance call, press **REDIAL** key twice, the telephone will auto-add “0” and dial out the number displayed on LCD. If the line is busy, press **REDIAL** key to dial out the number repeatedly.

➤ **Delete incoming call**

1. Review the desired incoming number.
2. Press **DEL** key to delete the number, then LCD displays the next number.

Note: Press **DEL** key for 3 seconds, all the incoming message will be erased.

REVIEW, CALL BACK AND DELETE OUTGOING CALL

The phone can record 5 outgoing messages, sequence number and conversation time. You may review, call back and delete outgoing calls. If over 5 outgoing calls, the earliest one will be replaced. When you review outgoing call, LCD will not display real date and time, but display the conversation time.

➤ **Review outgoing call**

1. In on-hook or off-hook state.
2. Press **OUT** key, LCD displays the last dialed number.
3. Press **OUT** key continuously, LCD displays **...END...** after all outgoing numbers are reviewed.

➤ **Dial back outgoing call**

1. In on-hook or off-hook state.
2. Press **OUT** key to check the desired number.
3. Press **REDIAL** key, the number will be dialed out automatically.



➤ **Delete outgoing Call**

1. In on-hook or off-hook state, press **OUT** key to check the number.
2. Press **DEL** key to delete it and LCD displays the next number.

Note: Press **DEL** key for 3 seconds, all the outgoing calls will be erased.

SET NUMBER AS VIP

In on-hook state, review the desired incoming or outgoing number,

1. Press **VIP/P** key to set the number as VIP number. There will be an  icon displayed on LCD.
2. Press **VIP/P** key again, the VIP number will become to ordinary number and the  icon will disappear.
3. The number set as VIP number can not be deleted, but when press **DEL** key for 3 seconds, all numbers will be deleted including the VIP numbers.

Notes:

1. When the number stored full, the unit will auto-cover the earliest ordinary one except of VIP number.
2. But if the numbers are all set as VIP number and the memory is full, the unit'd auto-cover the earliest VIP number.
3. It will ring a special ringing tone when a VIP call comes.

MENU SETTING

SET DATE AND TIME

1. In on-hook state, press **SET** key, LCD displays **SET 1 DATE**.
2. Press **SET** key, the last two digits of year flash.
3. Press **▲** or **▼** key to edit the year, press **SET** key to confirm, by using the same procedure to set the month, date, hour and minute.
4. Press **DEL** key to quit.

Note: Month: 1-12 Date: 1-31 Hour: 00-23 Minute: 00-59

SET LOCAL AREA CODE

1. In on-hook state, press **SET** key and then press **▲** key, LCD will display **SET 2 CODE**
2. Press **SET** key again, LCD displays **CODE - - - - -**
3. Press **▲** or **▼** key to set the first digit of local area code.
4. Press **SET** key to confirm and enter the second digit setting, follow same steps to set the last 4 digits.

5. Press **DEL** key to quit.

Note: If the local area code only 4 digits, the last digit can be left as “-”.

After set the local area code, unit will auto-filter the area code if the incoming call number with the first several digits as same as the local area code.

SET PABX CODE

1. In on-hook state, press **SET** key and then press **▲** key 2 times, LCD will display **SET 3 PCODE**.
2. Press **SET** key to confirm, LCD displays **PCODE --**, the first “-“flash and indicate to set the first digit of PABX code.
3. Press **▲** or **▼** key to set the PABX code. Press **SET** key to confirm and enter the second digit setting.
4. Following same steps to set the second digit.

Notes:

1. If only one digit of PABX code, left the second digit as“-“.
2. If set PABX code, when dialing back incoming call or pre-dial a number, and if the number is 6 digits or more than 6 digits, the telephone will auto-add PABX code ahead the incoming number or the pre-dialing number which is not lead by PABX code and then pause 1 second.

SET AUTO IP

In on-hook state, press **SET** key and then press **▲** key 3 times, LCD will display **SET 4 AUTO IP**.

Note: This function is unavailable, so the users do not need to set this item.

SET DIALING TYPE

1. In on-hook state, press **SET** key and then press **▲** key 4 times, LCD will display **SET 5 P-T**.
2. Press **SET** key to confirm, LCD displays **TONE**, press **▲** or **▼** key to select **TONE** or **PULSE**.

SET ANTI-DIALING FUNCTION

1. In on-hook state, press **SET** key and then press **▲** key 5 times, LCD displays **SET 6 ALAR**
2. Press **SET** key to confirm, LCD displays **ALAR OFF**, press **▲** or **▼** key to select **ON** or **OFF**.
3. Press **SET** key to confirm.

When the anti-dialing is set to ON, users who want to dial using an extension (parallel phone) via the same line will hear a “DI-DI, DI-DI” beep continuously and will not be allowed to make a call.

SET LCD CONTRAST

1. In on-hook state, press **SET** key and then press **▲** key 6 times, LCD displays **SET 7 LCD**
2. Press **SET** key to enter, LCD displays **LCD 3**, press **SET** to enter, LCD displays **LCD 3**, press **▲** or **▼** to select among 1~5 levels.
3. Press **SET** key to confirm and exit.

MUTE FUNCTION

During conversation, if you want to talk to someone else and you do not want the phone receiver hear your voice, press **MUTE/RING** key to mute your voice sending, LCD displays “**MUTE**”. To recover the conversation, press **MUTE/RING** key again.

SET RINGING TONE

There are 8 kinds of ringing tone for selection:

1. In on-hook state, press **MUTE/RING** key, LCD display **RING 01**.
2. Press **▲** or **▼** key to select ring tone.

Besides, you can also press **MUTE/RING** key repeatedly to select the ringer.

ONE-TOUCH MEMORY

Storing a number into one-touch memory

1. In on-hook state, pre-dial the desired number or review the incoming or outgoing list for the desired number to store.
2. Press **SET** key, then press **M1** key to store the number.

➤ Dial one-touch memory

In on/off-hook situation, press **M1** key to dial out the stored number. The telephone will add PABX code ahead the number if the number is 6-digit or more than 6-digit.

HANDS-FREE VOLUME

During the hands-free mode, press **VOL** key repeatedly to adjust the speaker volume. There are 2 levels for selection between **HI** and **LO**.

RECALL FUNCTION

The recall function of **FLASH** key can support some special network service, such as call waiting, transfer call, etc. These services require a subscription and the operations depend on the different exchanger.

PAUSE FUNCTION

If dial a number from PABX extension, press PABX number (normally "0" or "9") + **VIP/P** + desired number. When redial, need not dial PABX number and **VIP/P** key, just press **REDIAL** key.

NOTES

Please unplug telephone line when install or replace batteries.

TROUBLE SHOOTING

- ❖ **No voice**
 - ✓ Check if the handset is on the phone or line is broken.
- ❖ **Receive only**
 - ✓ Check if pulse or tone mode is properly set.
- ❖ **Battery rust or leak**
 - ✓ Replace the batteries.
- ❖ **Noise**
 - ✓ Check if the circuit is broken, change the circuit.
 - ✓ Check if the connector is moist or rust, change the connector.
- ❖ **Ring once then disconnect when receive a call. Dialing function is available**
 - ✓ Check if connector is in a moist environment.
 - ✓ Check if too many extensions are used together or the quality of extension is not good enough, change the bad extension.
- ❖ **Most of the functions failed**

- ✓ Check if the battery is in low-battery state, change the battery.
- ✓ Battery is in normal state, unplug the telephone line, remove the batteries, and reinstall after 10 minutes.



Waste electrical and electronic equipment are a special waste category, collection, storage, transport, treatment and recycling are important because they can avoid environmental pollution and are harmful to health. Submitting waste electrical and electronic equipment to special collection centers makes the waste to be recycled properly and protecting the environment. Do not forget! Each electric appliance that arrives at the landfill, the field, pollutes the environment!



Importer & distributor:

SC VITACOM ELECTRONICS SRL

CIF: RO 214527

Tel. 0264-438401*

sales@vitacom.ro, www.vitacom.ro